



Art Complex Replacement

LITTLE + GRIMSHAW

COMMUNITY OUTREACH PRESENTATION | MAY 20TH, 2020

Programming and Concept Design

Schematic Design

Design Development

Contract Documents

District of the State Architect





Bidding

Contract Administration

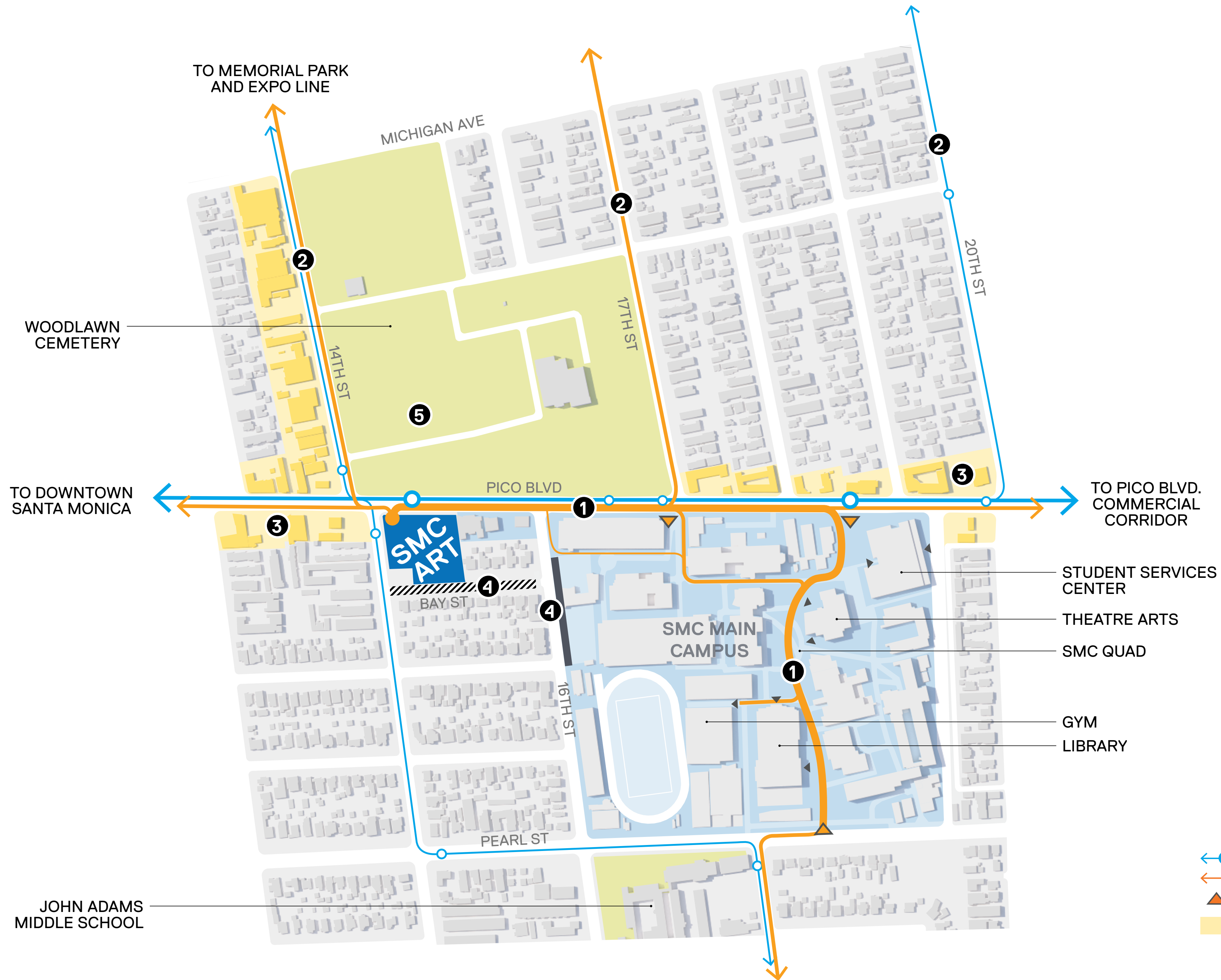
12/3/19	Board of Trustees Presentation
12/10/19	User Group Kickoff Meeting
12/19/19	Existing Facilities Site Visits
1/10/20	Coffee and SMC CMD Tour with Walter Meyer
1/30/20	User Group Programming Workshop
2/13/20	User Group Concept Design Workshop 1
2/20/20	User Group Concept Design Workshop 2
4/6/20	User Group Design Update
4/8/20	Maker Space Meeting
4/21/20	President's Presentation

Project Site



-  Bus Routes and Stops
-  Pedestrian Routes and Bike Lanes
-  Campus and Building Entries
-  Neighborhood Commercial Areas

Site Extents

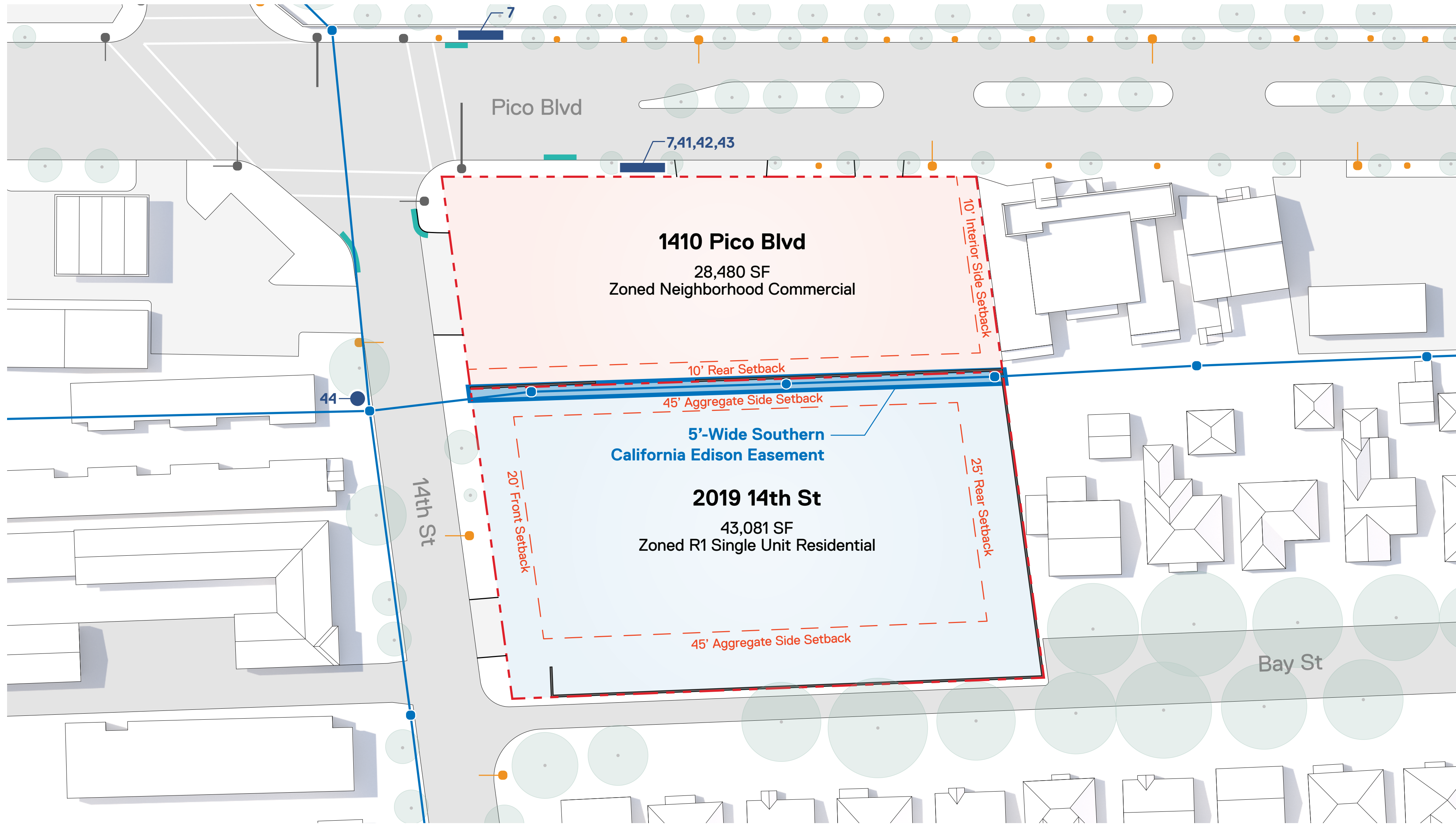

- Street Lights
- Traffic Lights
- Overhead Utility
- Storm Drains
- Bus Stops
- ▬ Curb Cuts on Site
- Trees

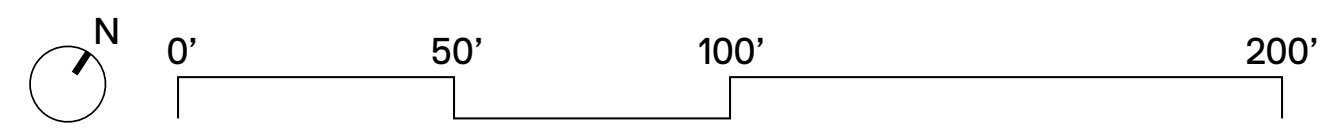

Programming and Concept

Inclusive and Welcoming Design

Flexible and Adaptive Spaces

Evolving methods of Teaching

Fluid Design Workflows

Discipline Agnostic Creativity

Facilitate Collaborative Outcomes

1,825 ASF

CLASSROOM

17,203 ASF

LABORATORY

1,692 ASF

OFFICE

Other Spaces
within GSF

CIRCULATION / BREAKOUT

EXHIBITION / COMMON USE

TEACHING

LECTURE

BREAK
OUT

CREATING

STUDIOS

HEAVY WORKSHOPS

LIGHT WORKSHOPS

STORAGE

SHARED OFFICES

OFFICES

SOCIAL

GATHERINGS

EXHIBITION

Current Organization Model

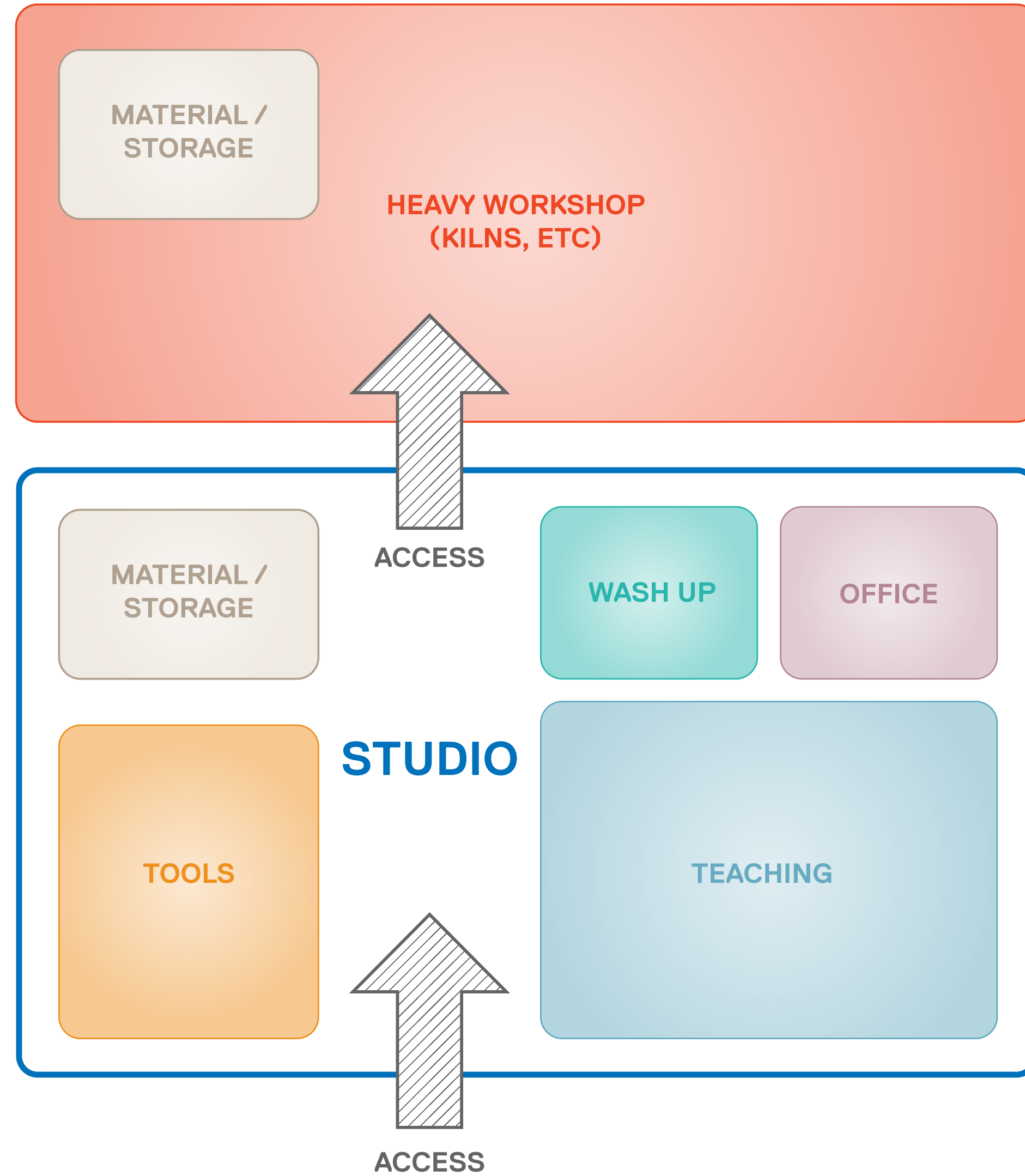

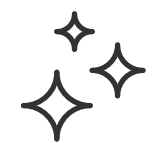
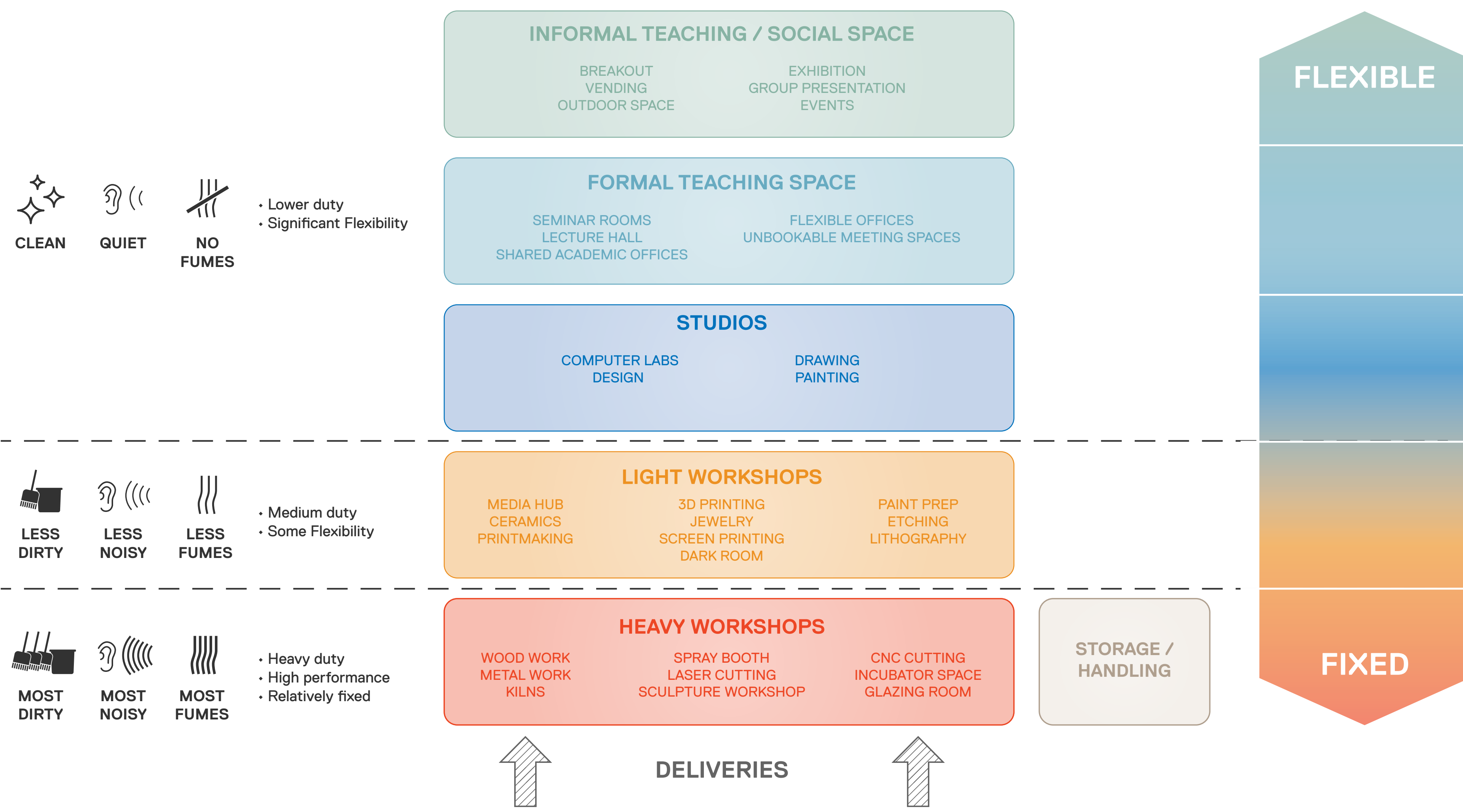

CLEAN



QUIET



NO FUMES

- Lower duty
- Significant Flexibility



LESS DIRTY



LESS NOISY



LESS FUMES

- Medium duty
- Some Flexibility



MOST DIRTY



MOST NOISY



MOST FUMES

- Heavy duty
- High performance
- Relatively fixed

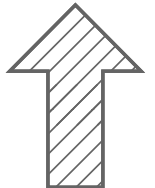

DELIVERIES

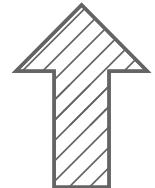

STORAGE / HANDLING

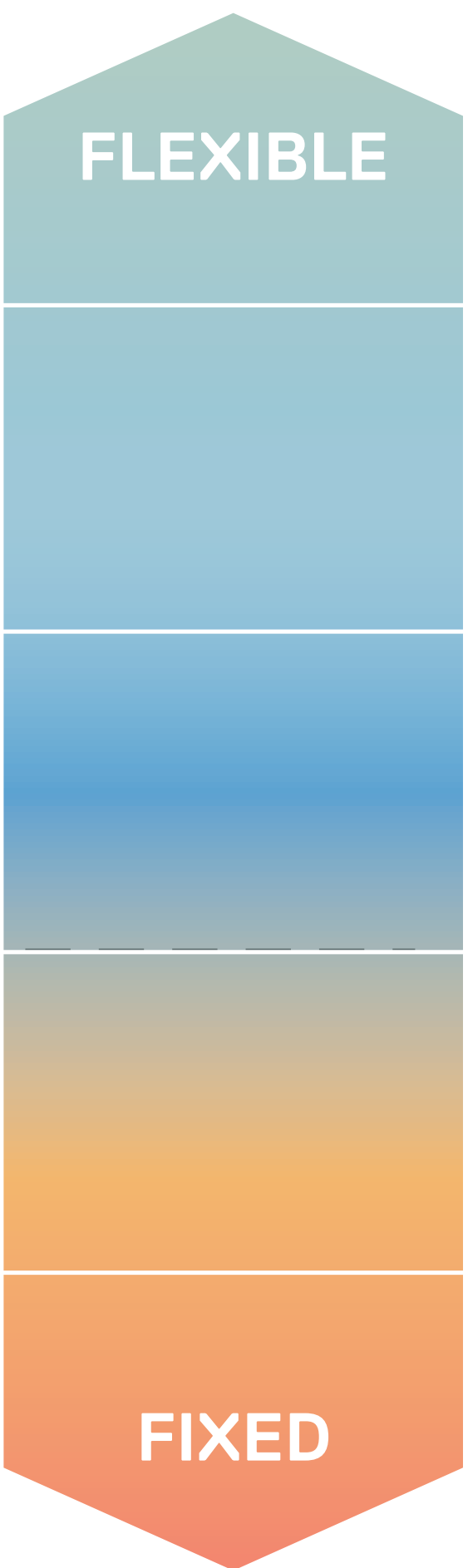

Bath School of Art & Design

Light Workshops



Schematic Design

1

INTERLOCKING

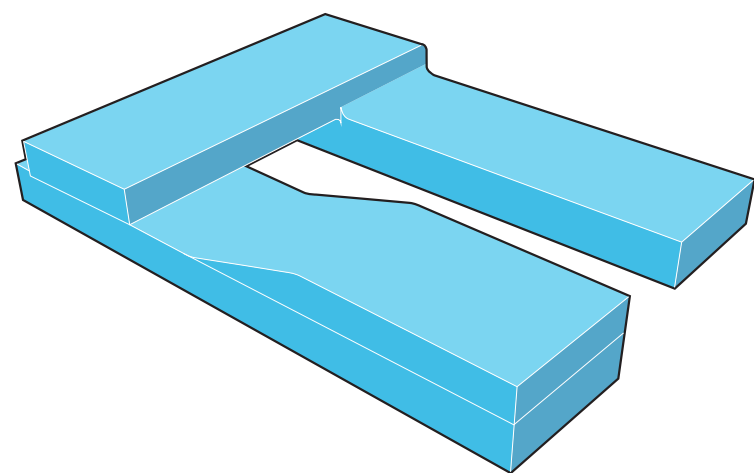

2

THE LEDGE

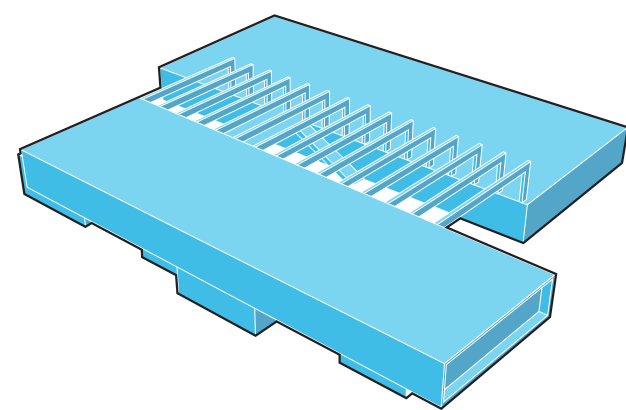

3

THE RAMP

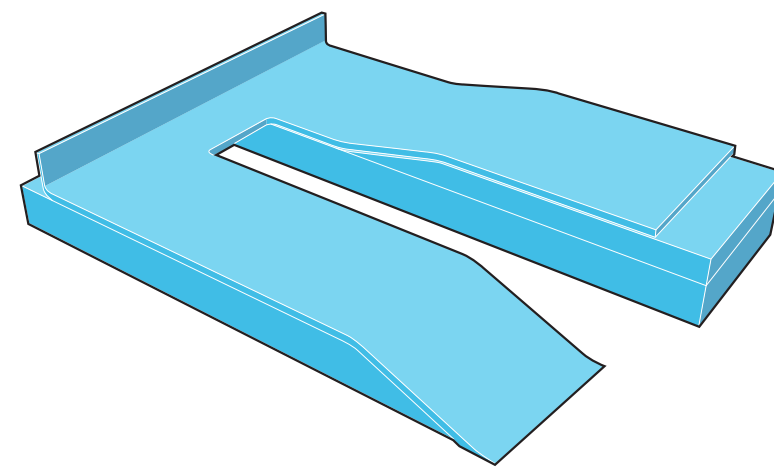

4

THE BIG BOX

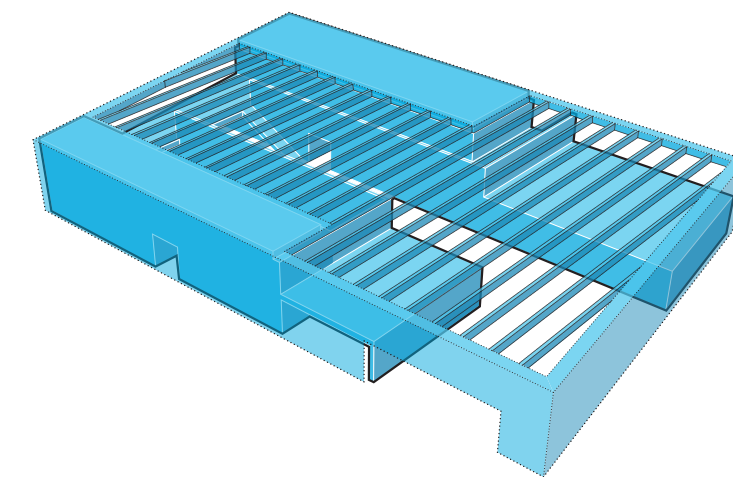

5

THE HANGARS

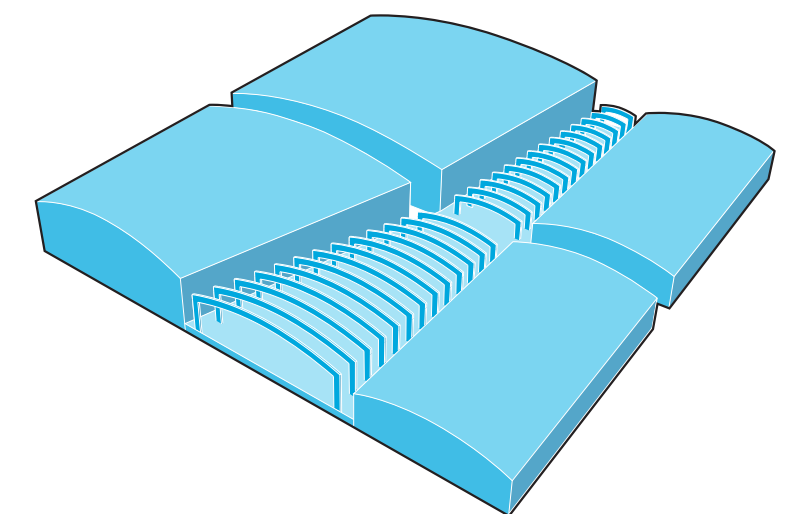

4

THE BIG BOX

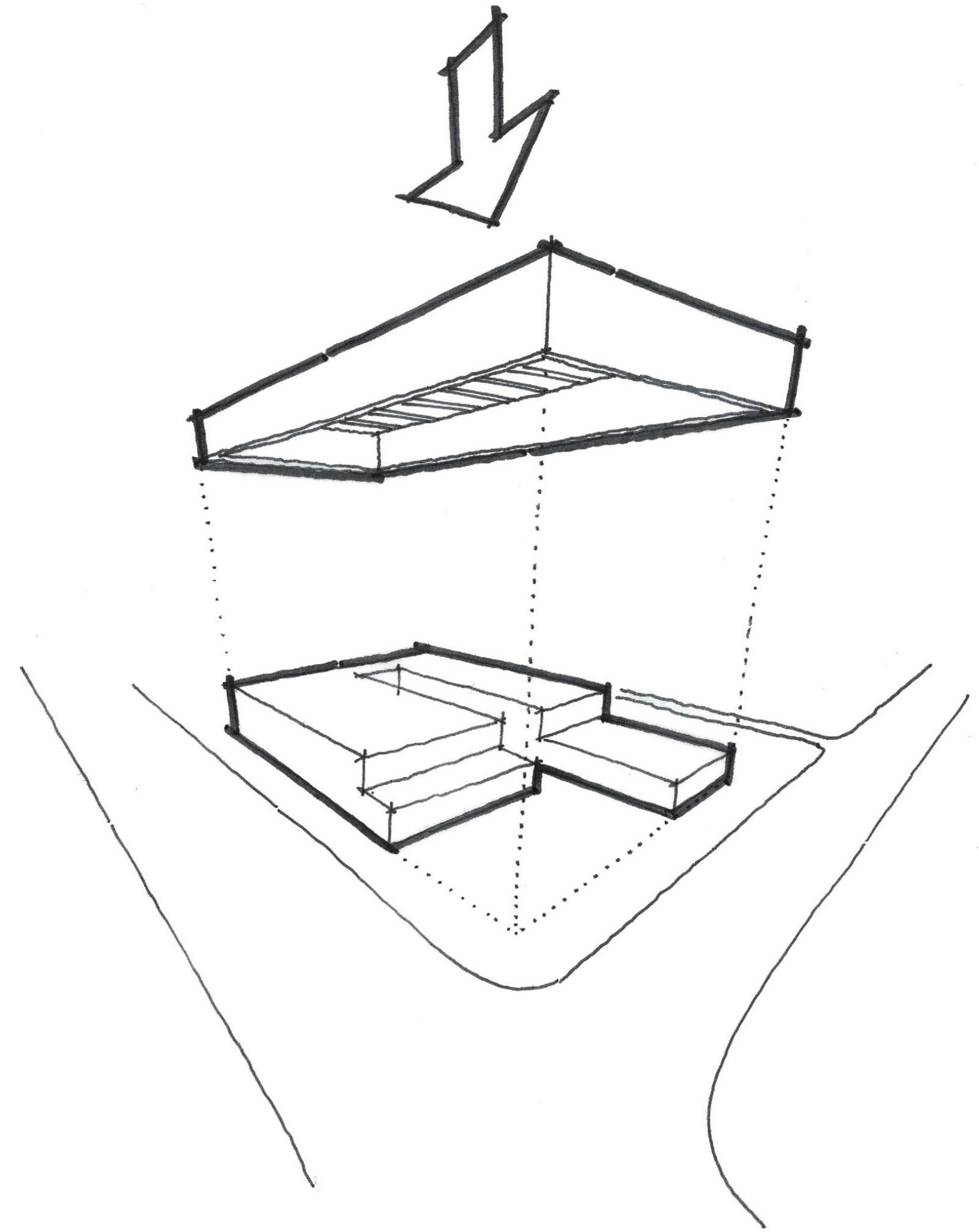
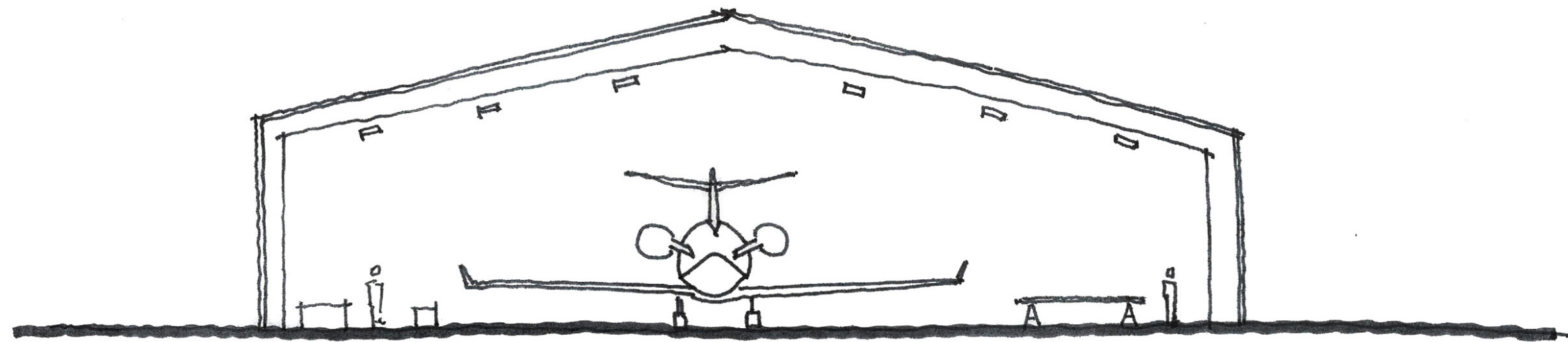

1

OCCUPY THE CORNER

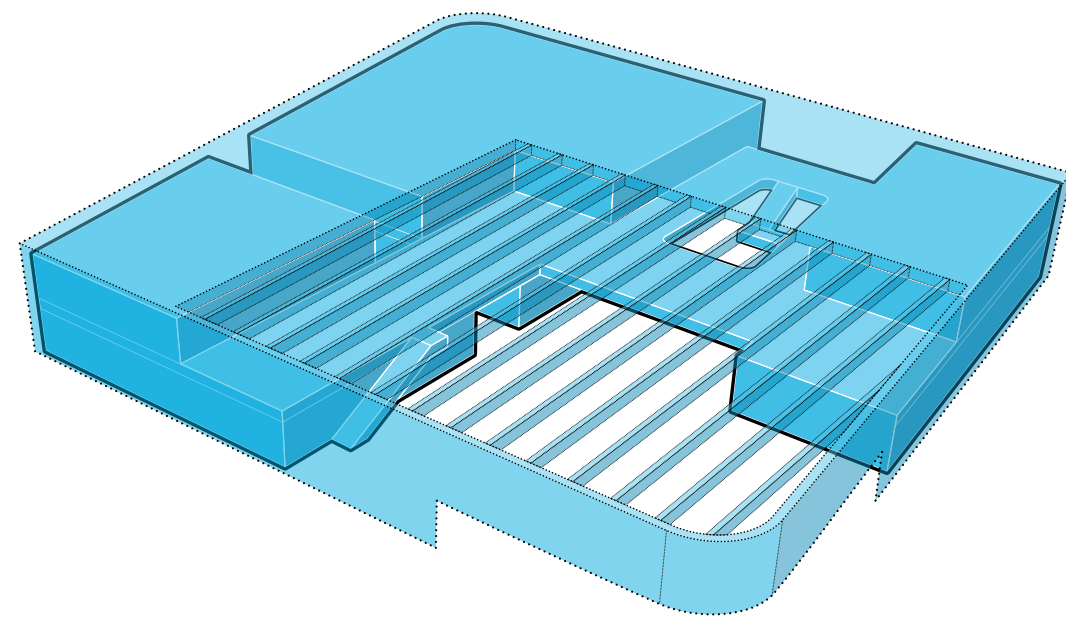

2

OPEN ARMS

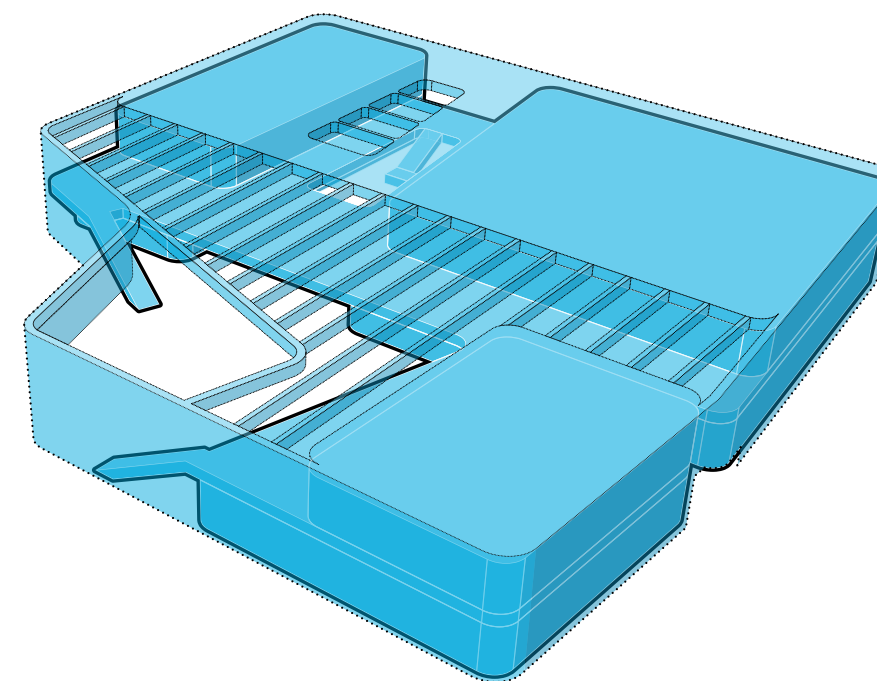

Site Organization

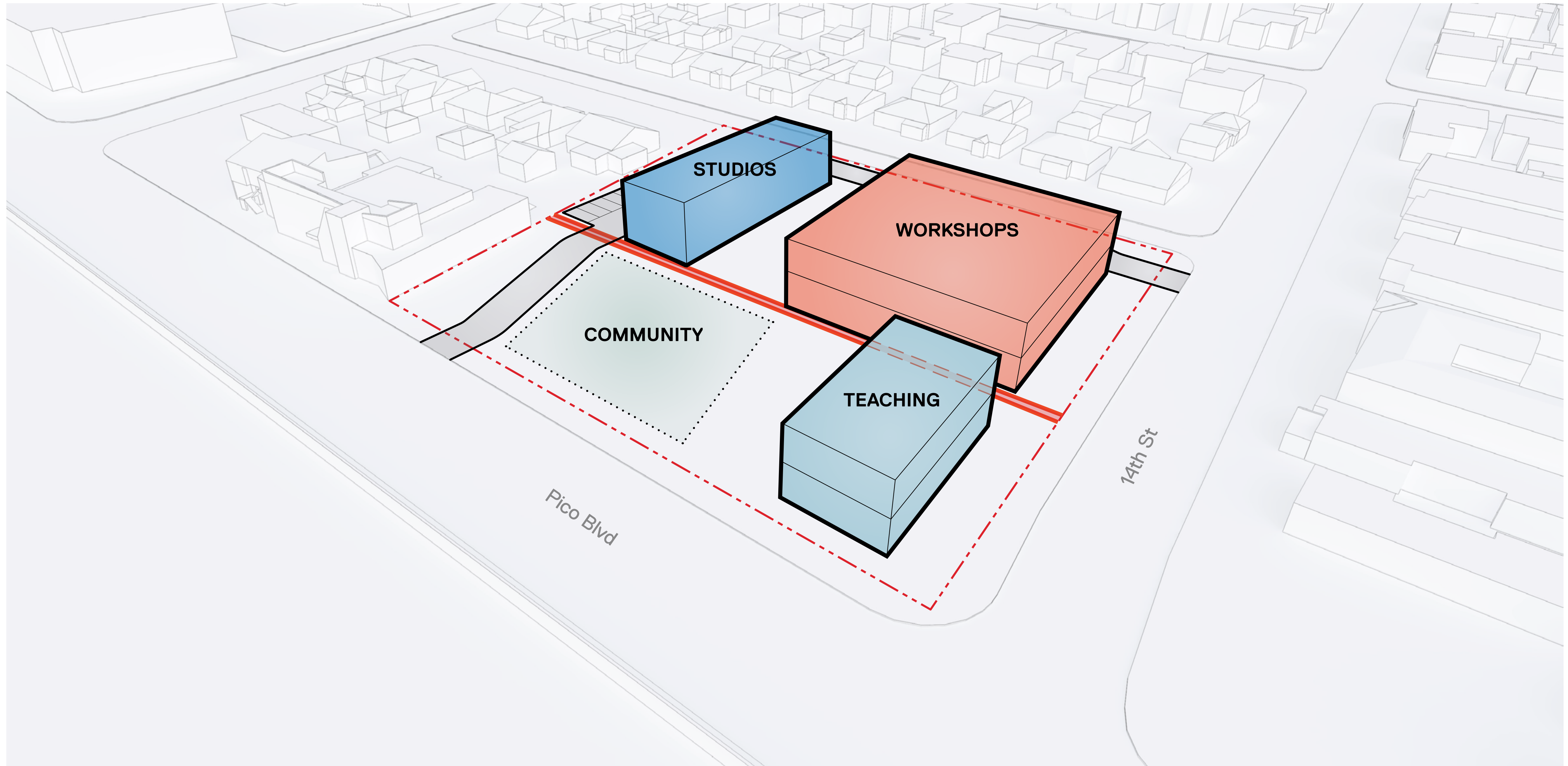

Initial Master Plan Vision

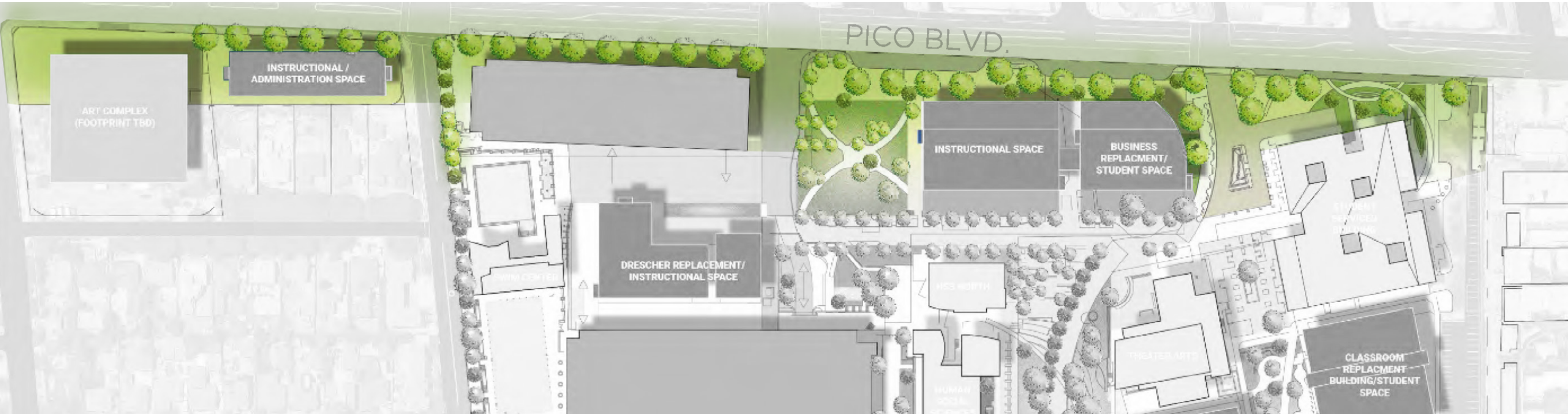

2

OPEN ARMS

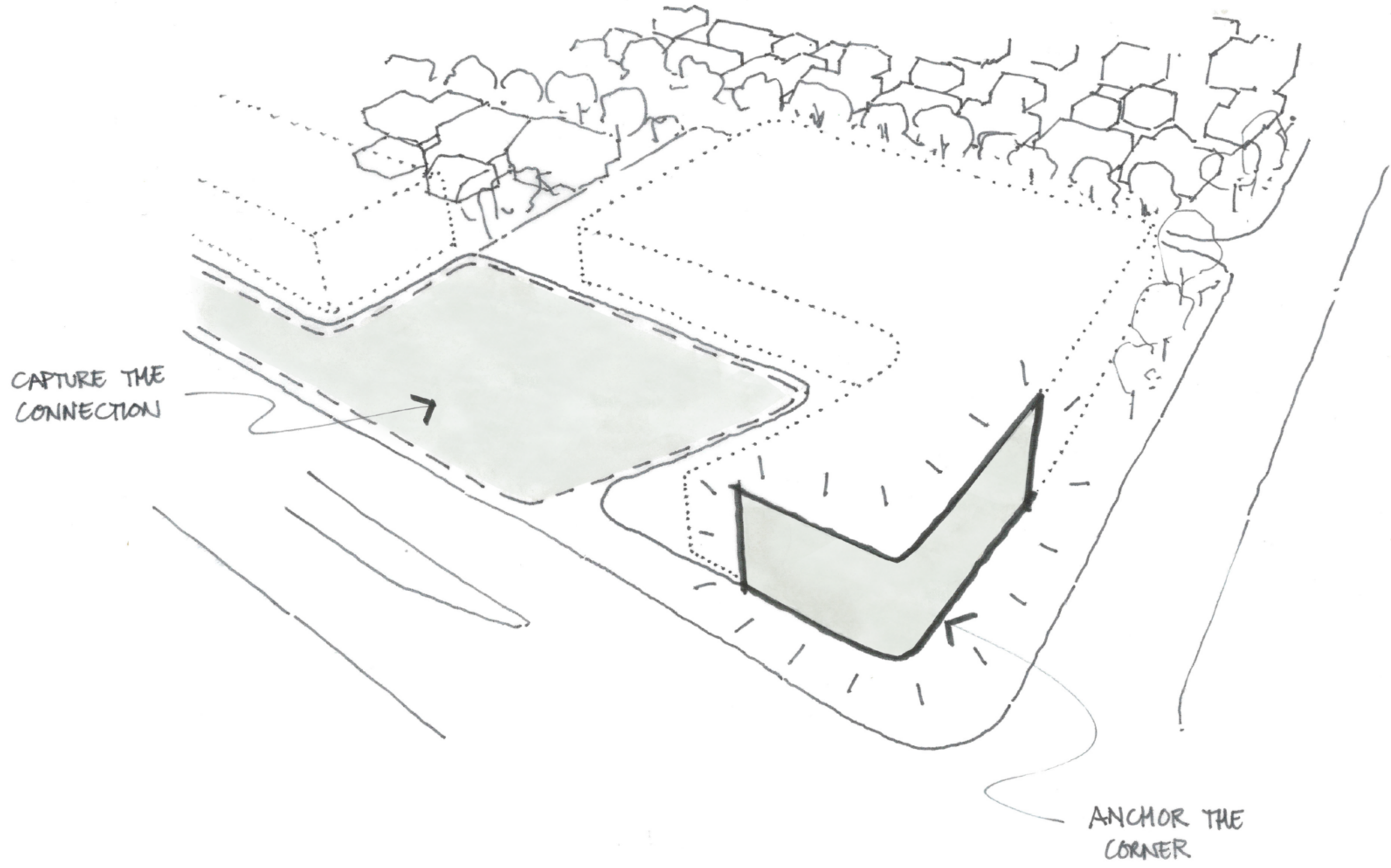

2

OPEN ARMS

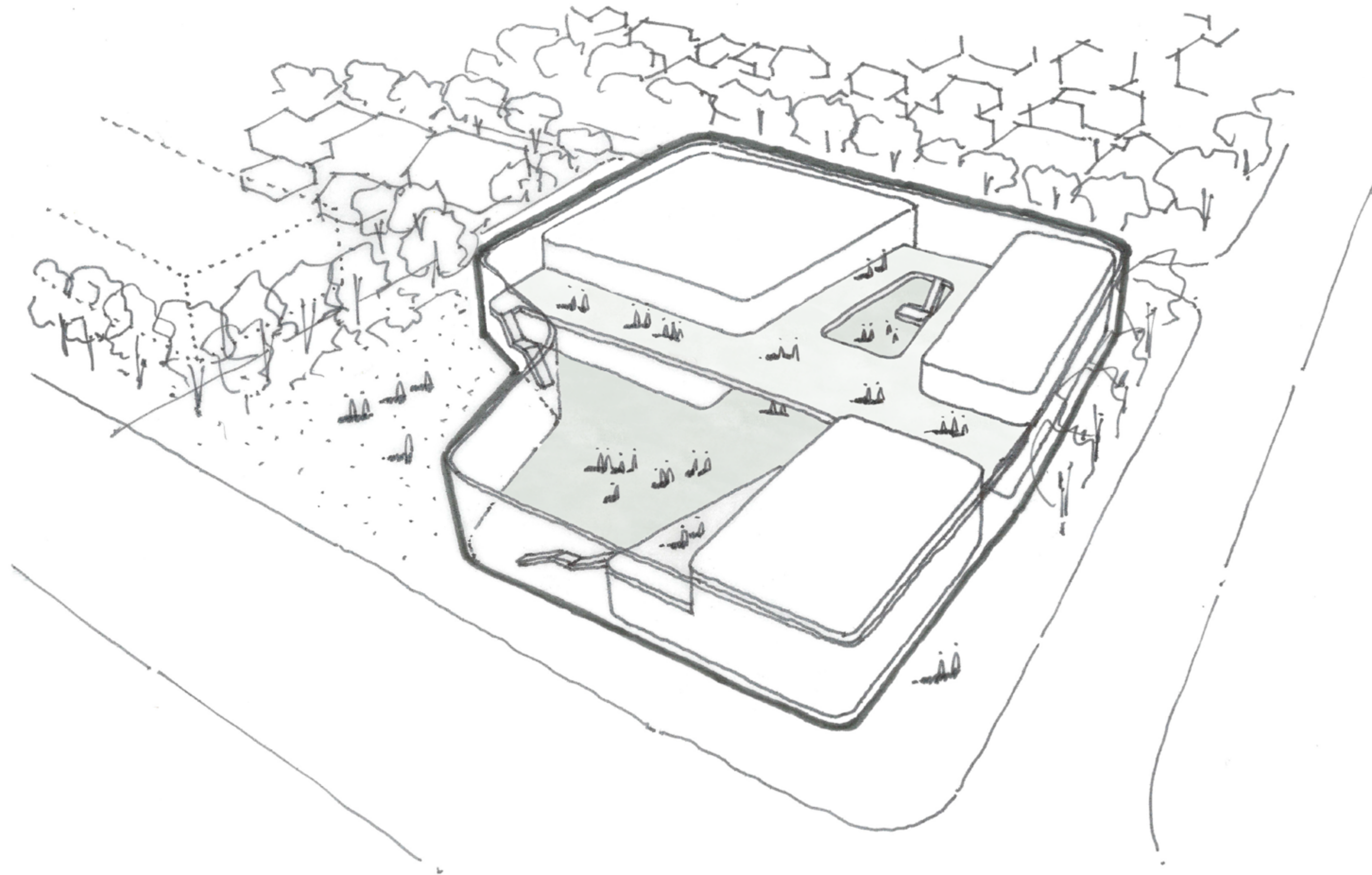

2

OPEN ARMS

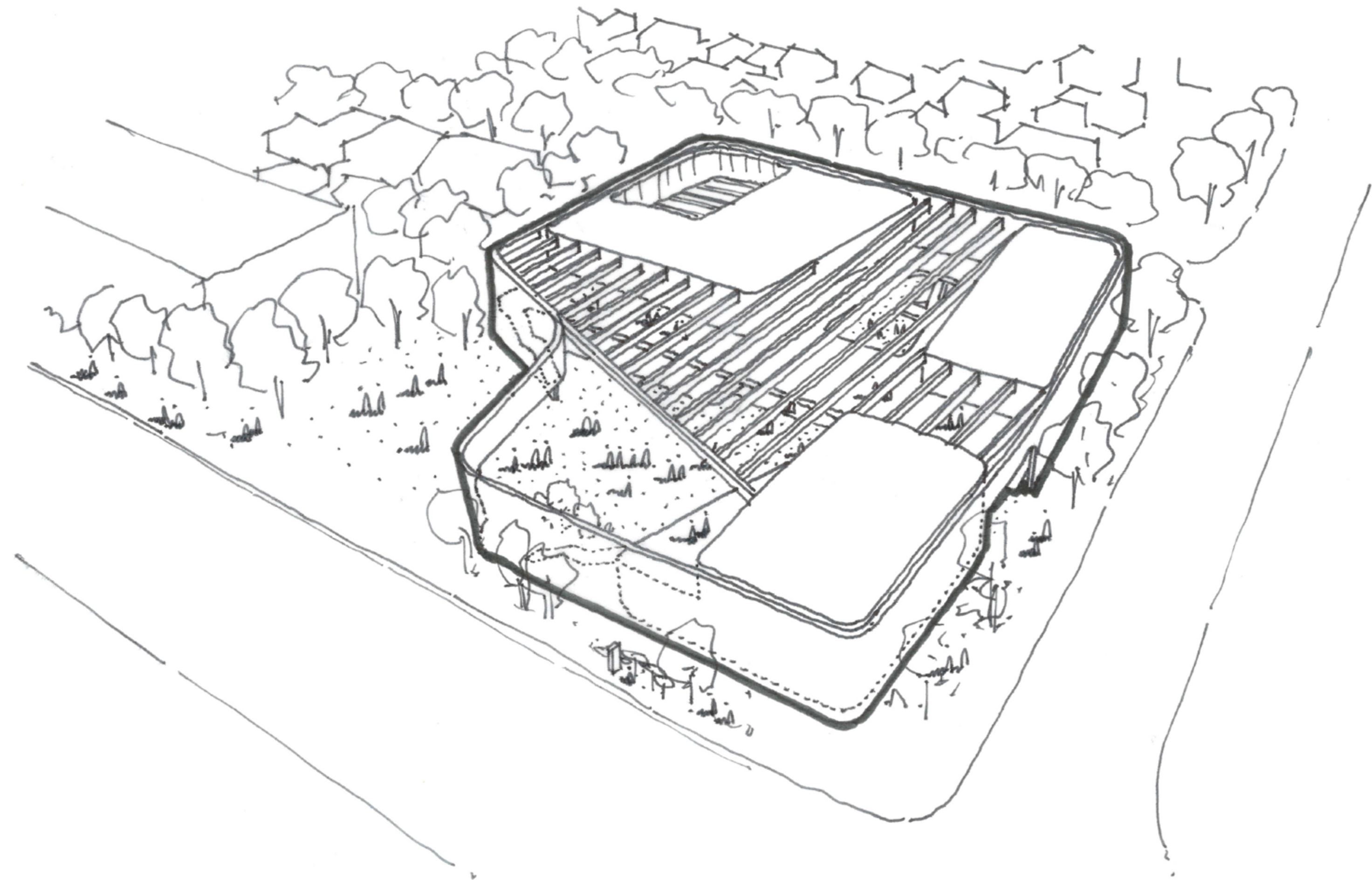

OPEN ARMS

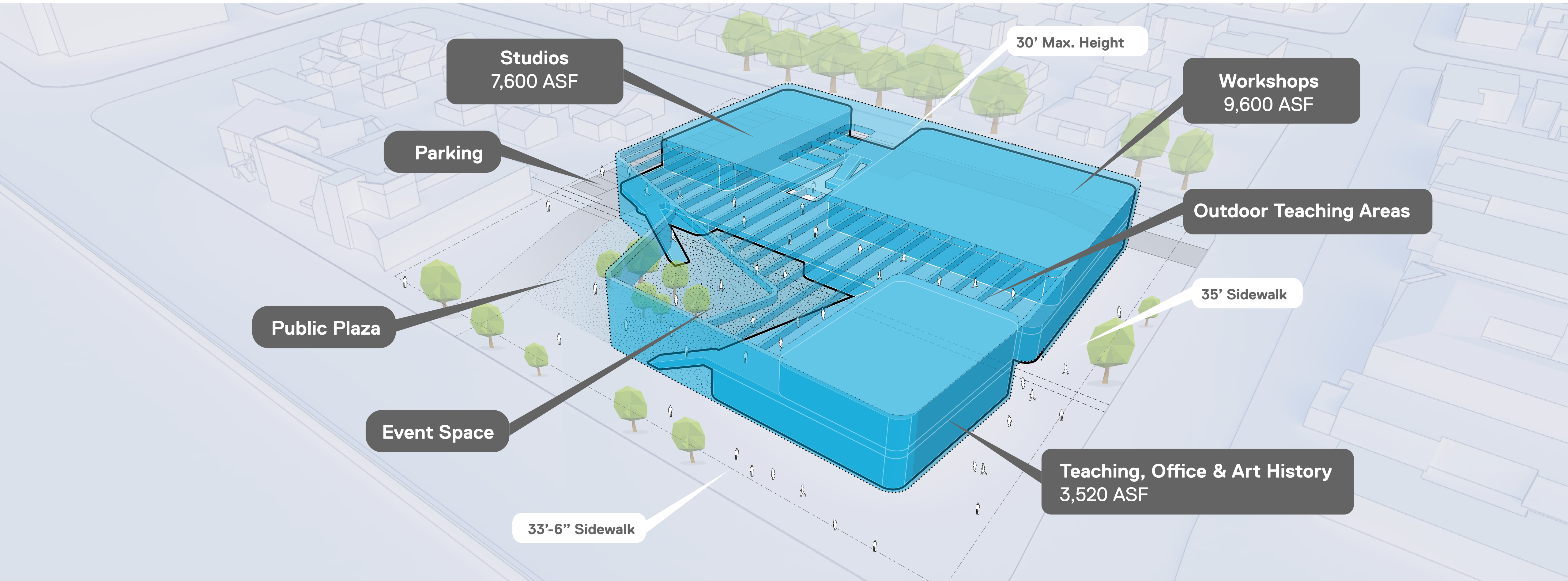

2

OPEN ARMS

LEVEL 1 ORGANIZATION

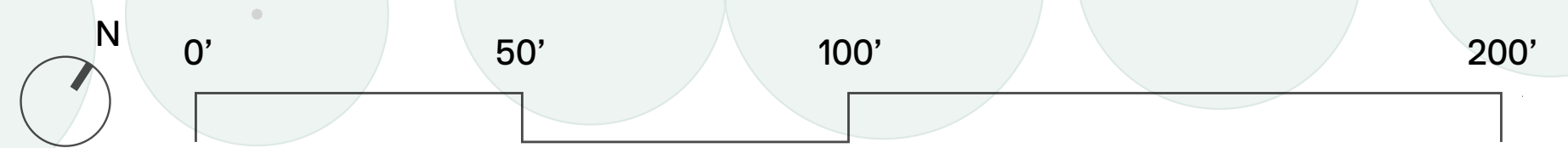

2

OPEN ARMS

LEVEL 2 ORGANIZATION

Pico Blvd

14th St

Bay St

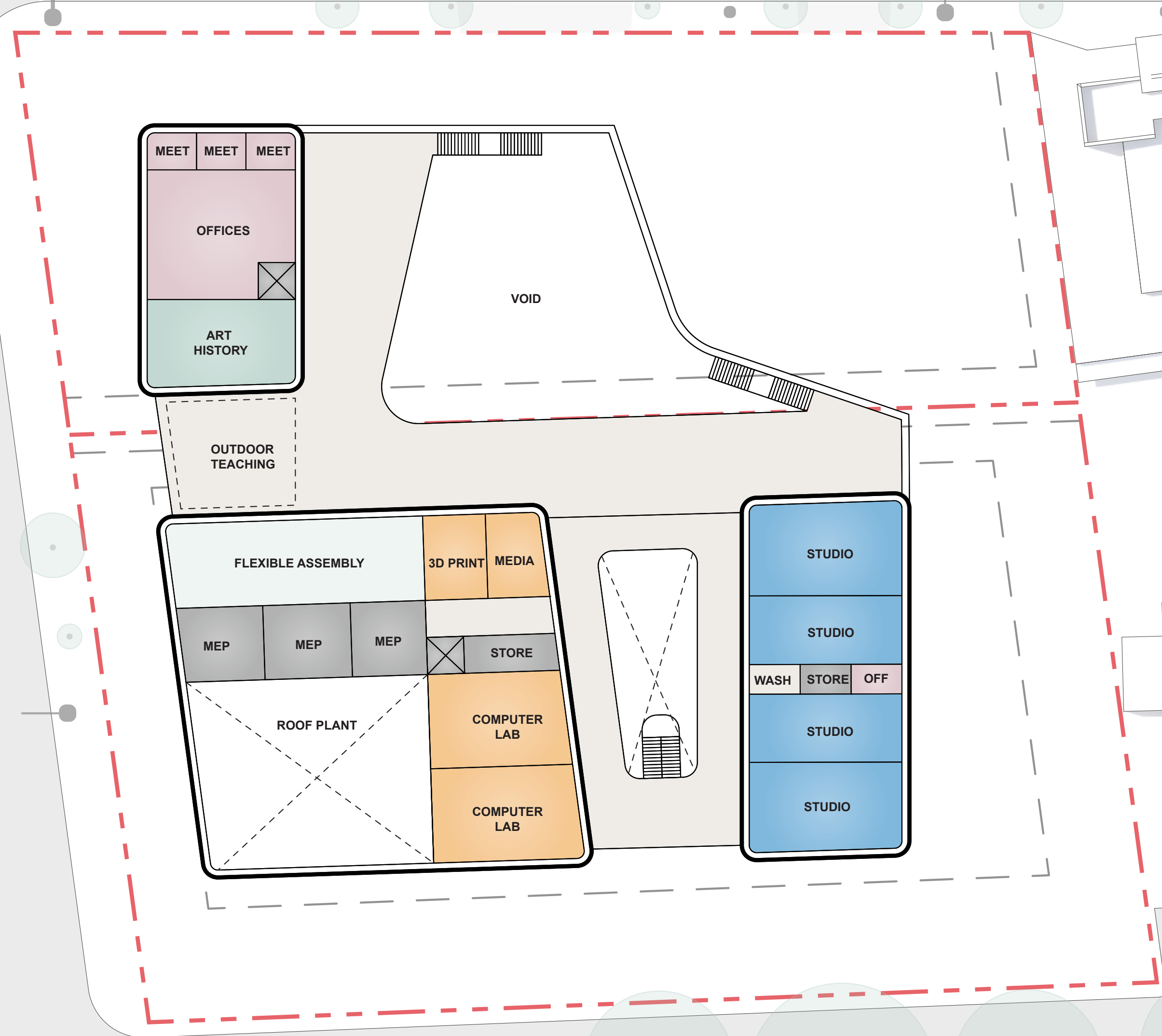

0' 50' 100' 200'



PICO BLVD

14TH ST

BAY ST



PICO BLVD

14TH ST

BAY ST



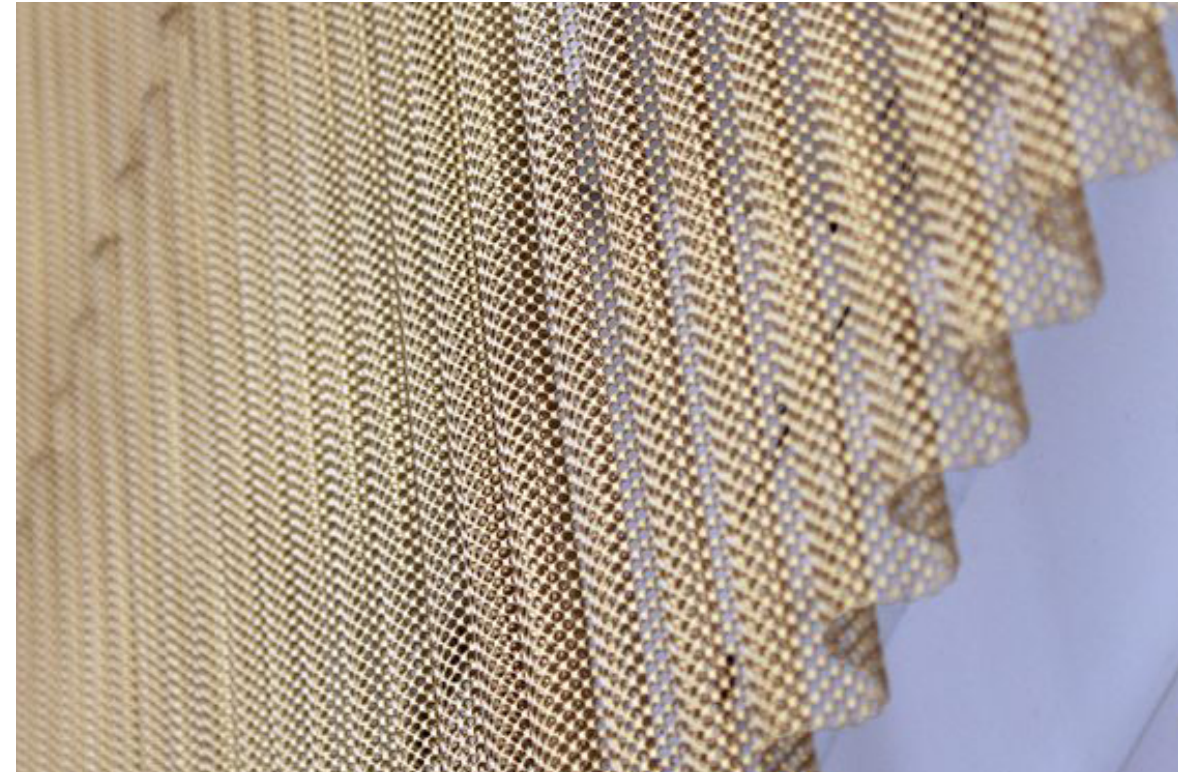



NO
OUTLET









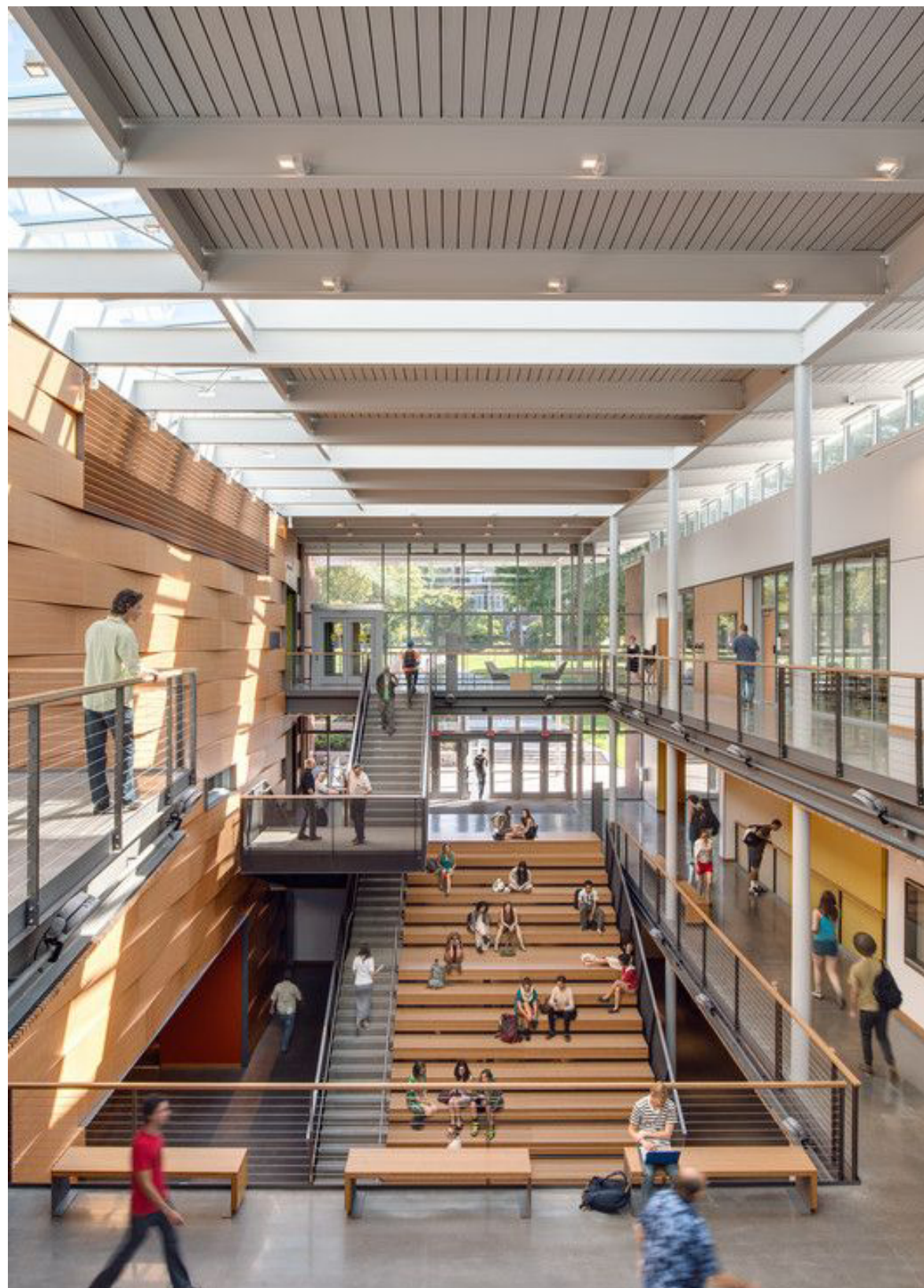
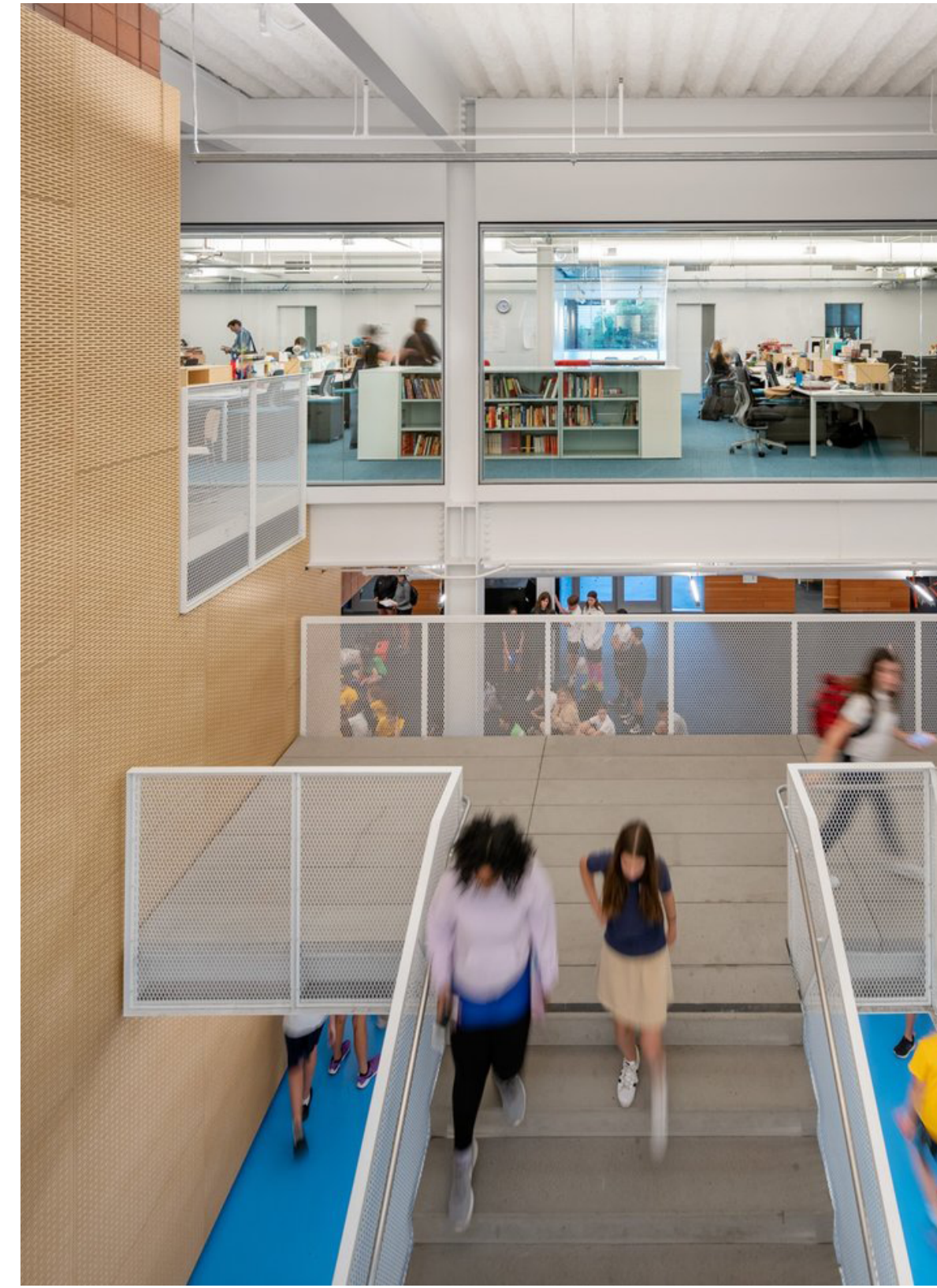



SANTA
MONICA
COLLEGE

Art Complex

Thank You

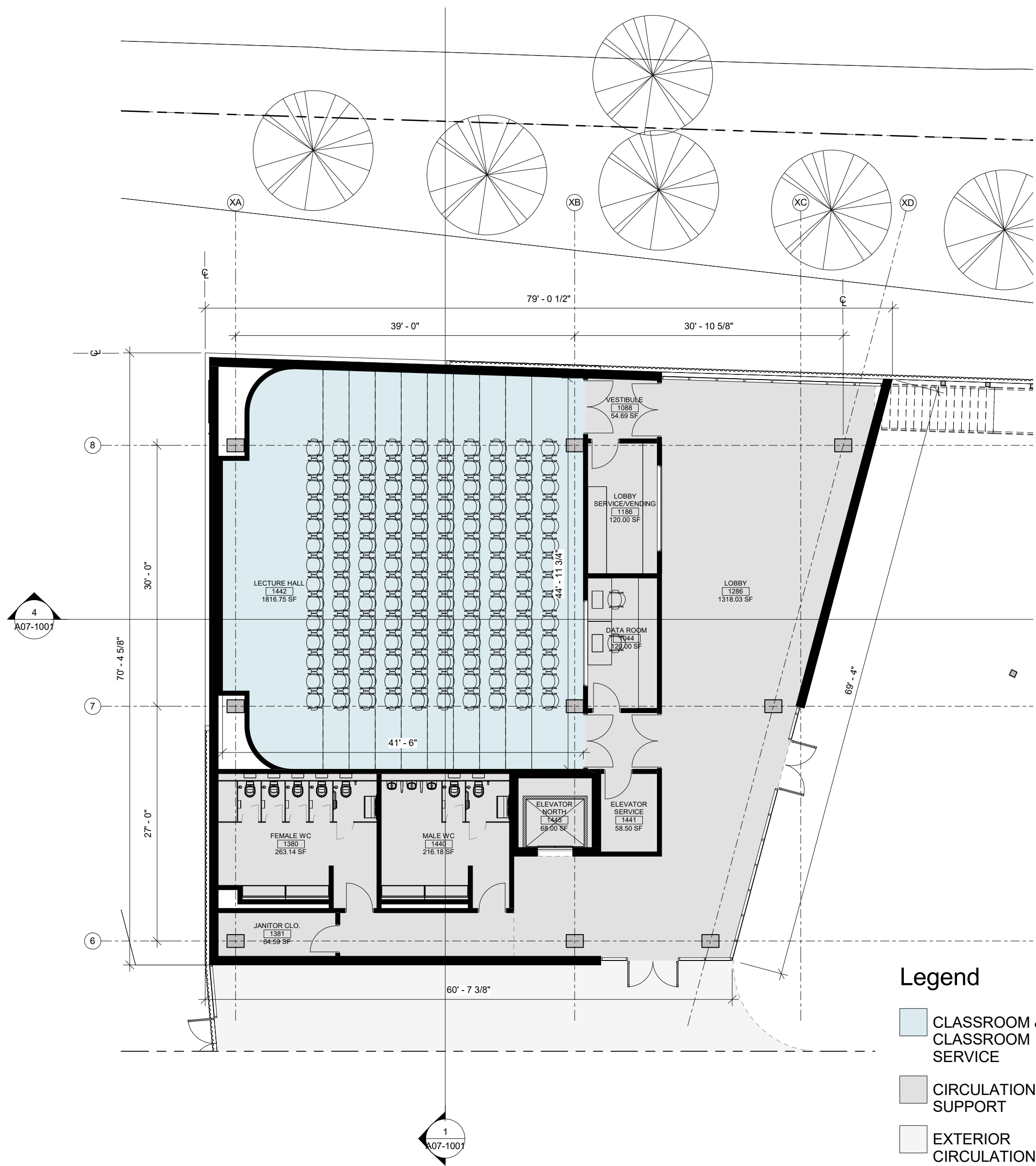

- Legend**
- CLASSROOM & CLASSROOM SERVICE
 - CIRCULATION & SUPPORT
 - EXTERIOR CIRCULATION

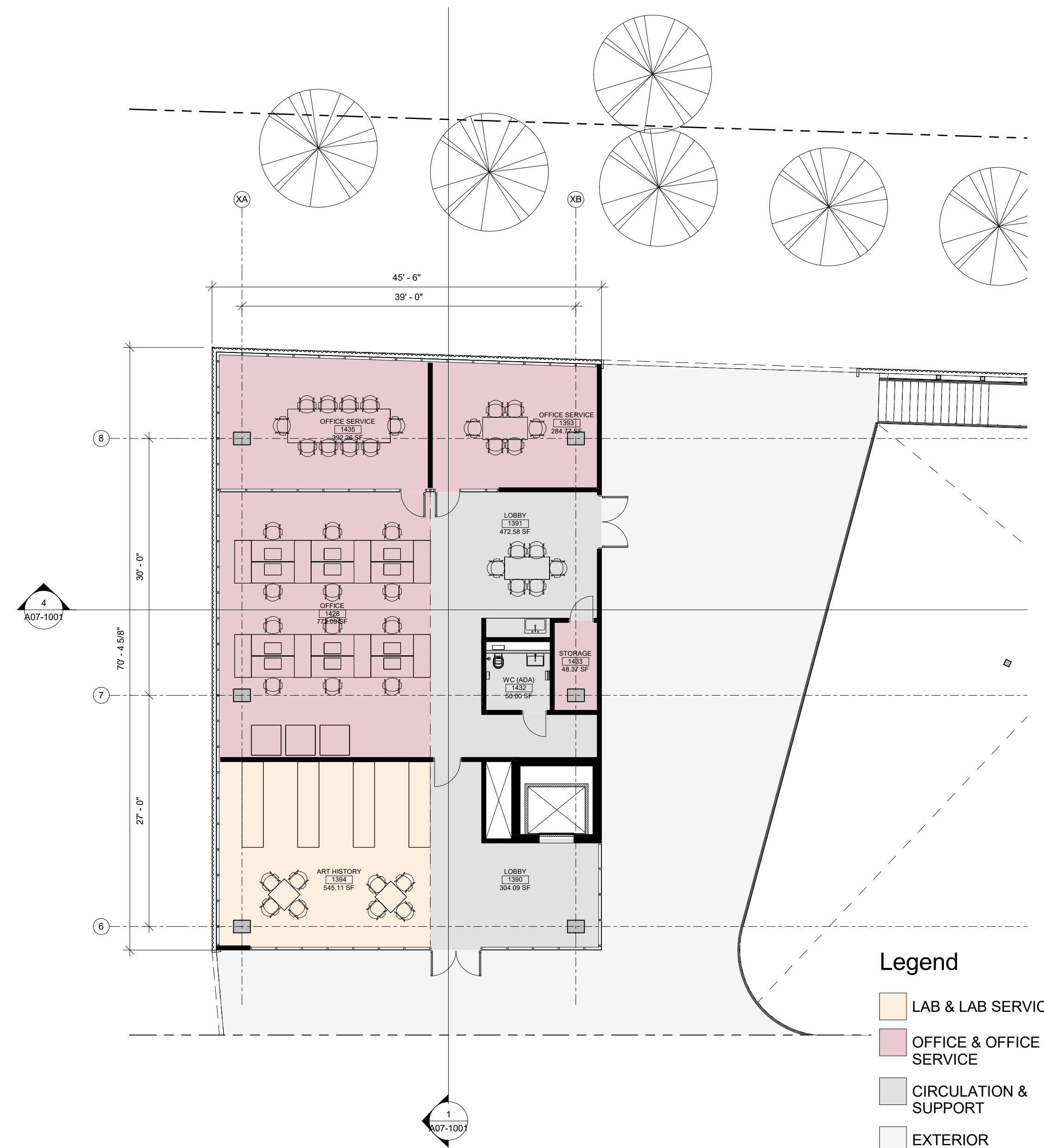

- Legend**
- LAB & LAB SERVICE
 - OFFICE & OFFICE SERVICE
 - CIRCULATION & SUPPORT
 - EXTERIOR CIRCULATION



- Legend**
- LAB & LAB SERVICE
 - CIRCULATION & SUPPORT
 - EXTERIOR CIRCULATION

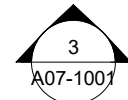

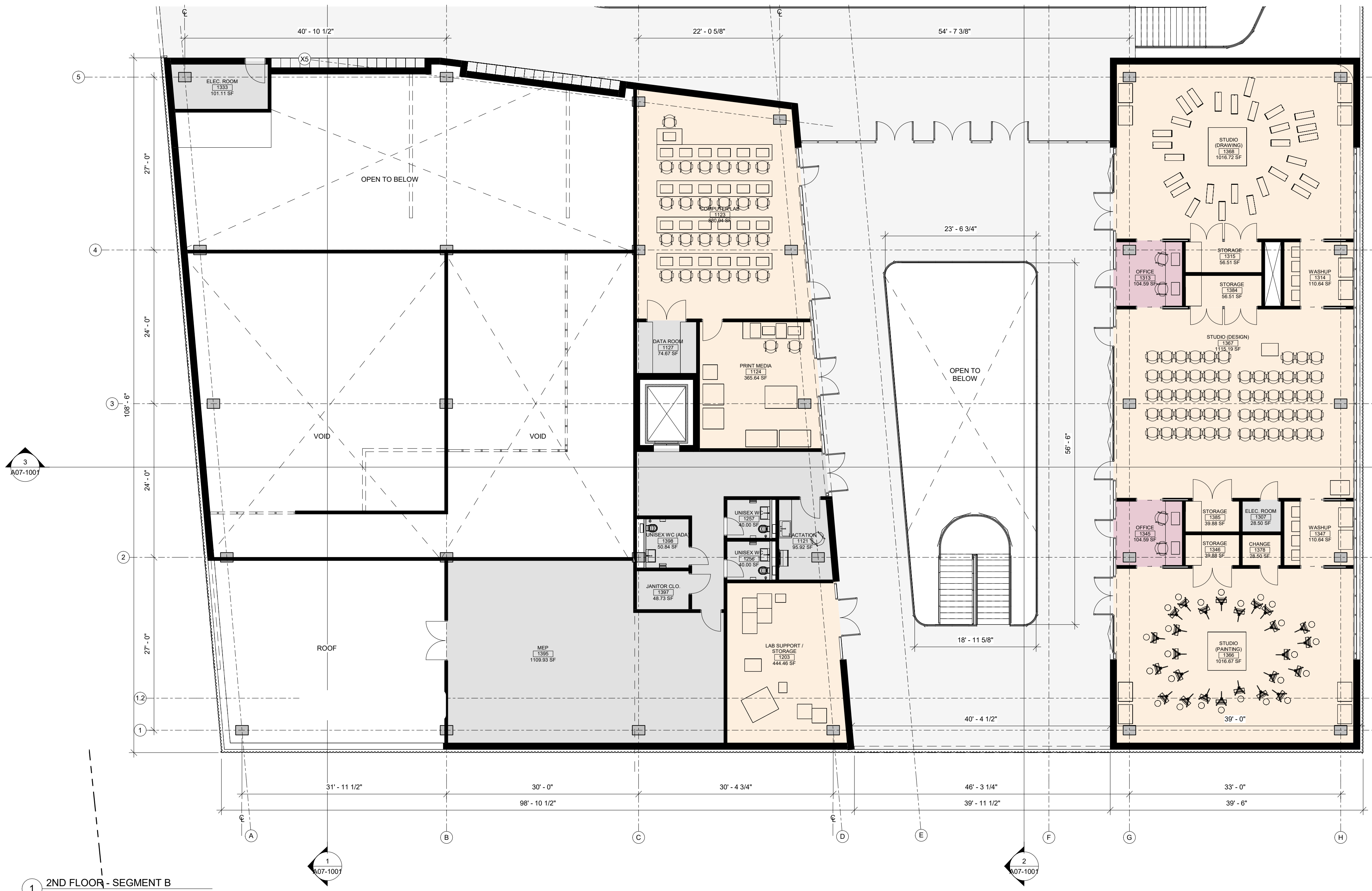

- Legend**
- LAB & LAB SERVICE
 - OFFICE & OFFICE SERVICE
 - CIRCULATION & SUPPORT
 - EXTERIOR CIRCULATION

1 2ND FLOOR - SEGMENT B
1/8" = 1'-0"

